

Install Instructions

Pull 01

350mm

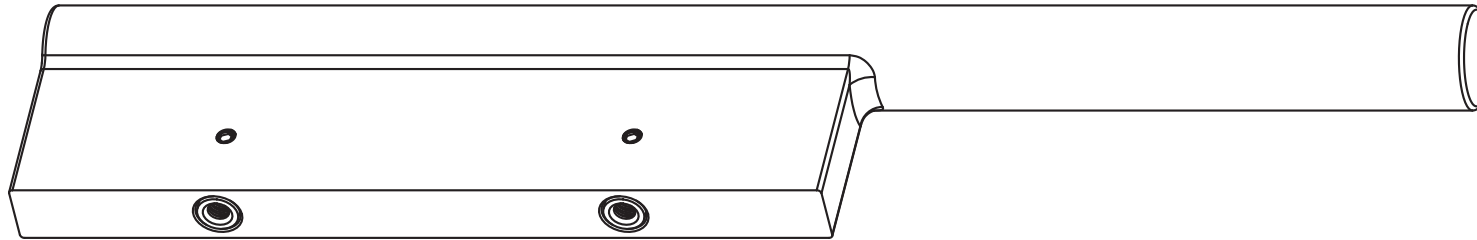

Scan for
Australian
Warranty



Scan for
New Zealand
Warranty



Scan for
Product &
Finish Care
Information



Contact Us
Southern Design Group

Australia
14 - 16 Stepney Street,
Stepney, South Australia 5069
P: +61 (0)8 8362 1133
info@bankstonarchitectural.com.au
bankstonarchitectural.com.au

New Zealand
P: +64 (0)6 359 0008
info@bankstonarchitectural.co.nz
bankstonarchitectural.co.nz

SDG Trading Pty Ltd
trading as Bankston Architectural
ACN 008 154 041
ABN 18 008 154 041

*Image used for illustration
purposes only.

1. Marking the Door

1.1 Mark the top fixing point on the face of your door at the desired height and horizontal distance from door edge. (Figure 1)

1.2 In most instances, the vertical position should align with the centre of the door stile on a panel door or with any lock, turn or escutcheon fitted to the door.(Figure 1)

1.3 Using a spirit level, mark the bottom fixing point – noting the CTC measurement is 100mm starting 50mm up from base of pull handle. (Figure 2)

2. Fitting the Pull Handle (Concealed Fix Method)

2.1 Remove the pencil spindles from the pull handle by loosening the grub screws. (Figure 3)

2.2 Drill appropriate pilot holes for the wood screws at each of the pencil spindle locations.(Figure 4)

2.3 Fit pencil spindles using wood screws provided. (Figure 4)

2.4 Place pull handle on pencil spindles and tighten grub screws to secure. (Figure 5)

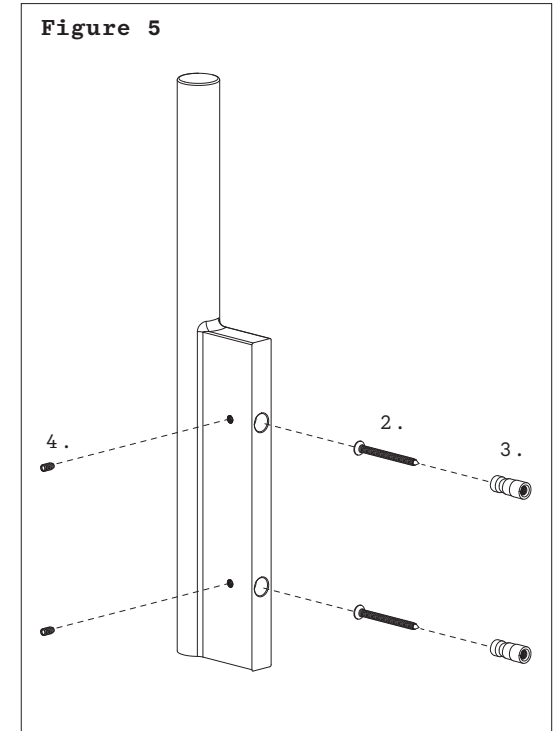
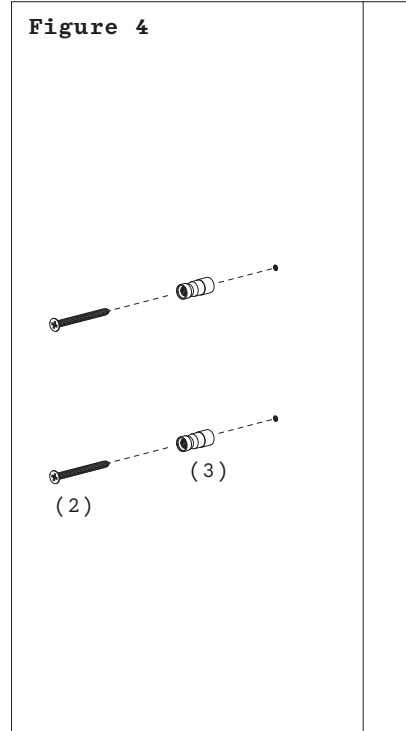
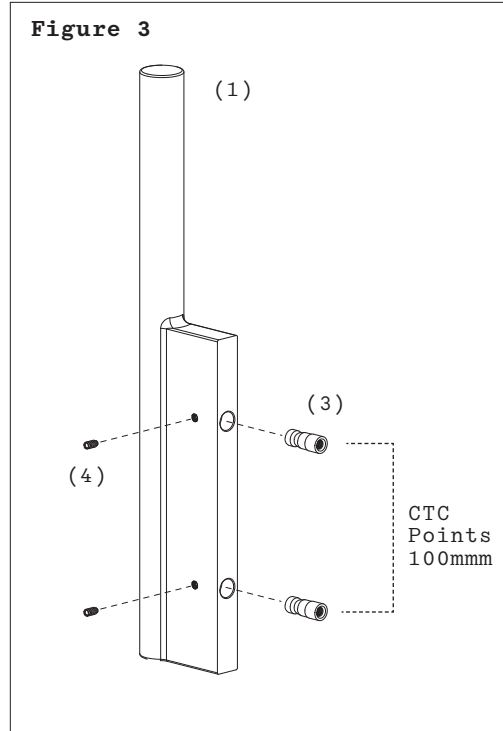
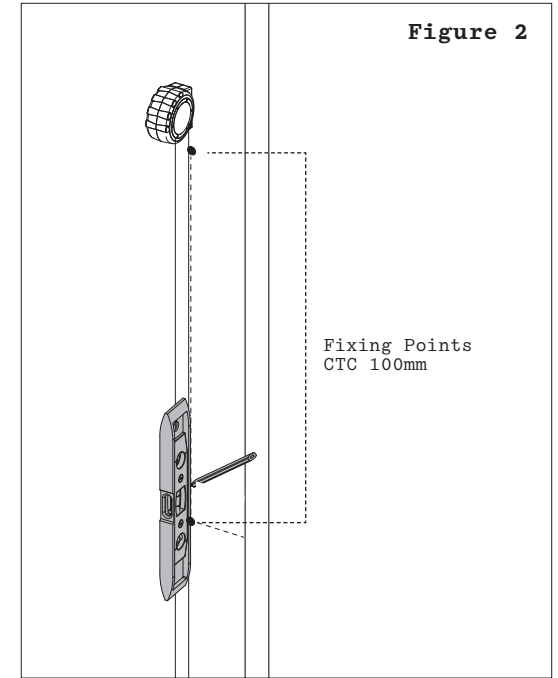
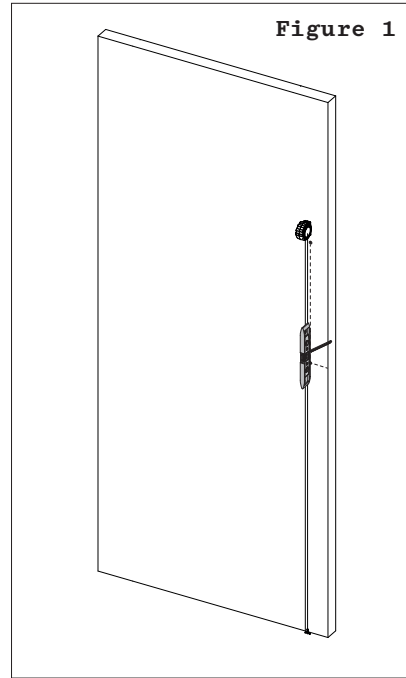

IMPORTANT:

Please install this hardware in the following order to ensure its warranty is not voided.

1. Install the hardware on raw/unfinished door using the instructions provided.
2. Remove hardware (where possible) and store safely. Do not place tape onto the hardware as this will damage the finish.
3. Paint / finish door.
4. Reinstall hardware.

For number references please refer to included items on reverse.

Included

1. Pull Handle

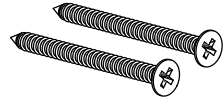
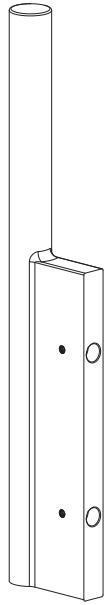

2. Wood Screws



3. Pencil Spindles



4. Grub Screws

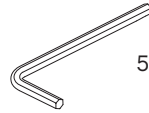

5. Allen Key

Not Included

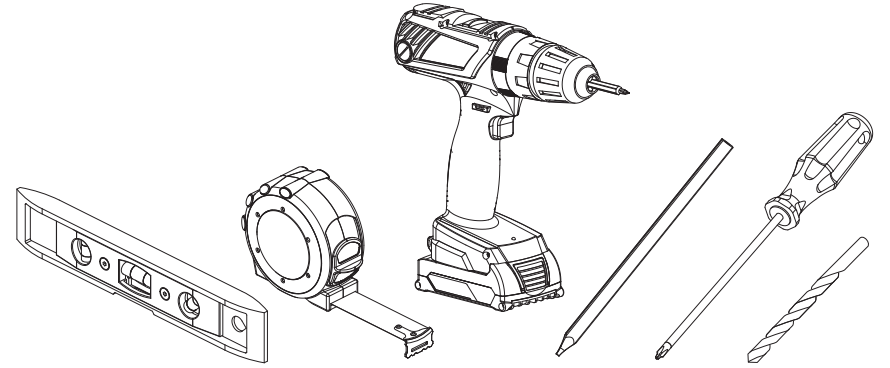

Dimensions

